



**SCHOOL  
COMMUNE**

**IITJEE (MAIN) - 2014**  
**(Physics, Chemistry and Mathematics)**  
**Code - E**

*Important Instructions:*

1. Immediately fill in the particulars on this page of the Test Booklet with Blue/Black Ball Pen Use of pencil is strictly prohibited.
2. The Answer Sheet is kept inside this Test Booklet. When you are directed to open the Test Booklet, take out the Answer Sheet and fill in the particulars carefully.
3. The test is of **3 hours** duration.
4. The Test Booklet consists of **90** questions. The maximum marks are **360**.
5. There are three parts in the question paper A, B, C consisting of Physics, Chemistry and Mathematics having 30 questions in each part of equal weightage. Each question is allotted 4 (four) marks for each correct response.
6. Candidates will be awarded marks as stated above in Instructions No. 3 for correct response of each question.  $\frac{1}{4}$  (one-fourth) marks will be deducted for indicating incorrect response of each question. No deduction from the total score will be made if no response is indicated for an item in the answer sheet.
7. There is only one correct response for each question. Filling up more than one response in each question will be treated as wrong response and marks for wrong response will be deducted accordingly as per instruction 4 above.
8. Use **Blue/Black Ball Point Pen** only for writing particulars/markings responses on **Side-1** and **Side-2** of the Answer Sheet. **Use of pencil is strictly prohibited.**
9. No candidate is allowed to carry any textual material, printed or written, bits of papers, pager, mobile phone, any electronic device, etc. except the Admit Card inside the examination hall/room.
10. Rough work is to be done on the space provided for the purpose in the Test Booklet only. This space is given at the bottom of each page and in 3 pages (Pages 21 - 23) at the end of the booklet.
11. On completion of the test, the candidate must hand over the Answer Sheet to the Invigilator on duty in the Room/Hall. **However, the candidates are allowed to take away this Test Booklet with them.**
12. The CODE for this Booklet is **E**. Make sure that the CODE printed on Side-2 of the Answer Sheet is the same as that on this booklet. In case of discrepancy, the candidate should immediately report the matter to the Invigilator for replacement of both the Test Booklet and the Answer Sheet.



**PART-A : PHYSICS**

- The current voltage relation of diode is given by  $I = (e^{1000V/T} - 1) \text{mA}$ , where the applied  $V$  is in volts and the temperature  $T$  is in degree kelvin. If a student makes an error measuring  $\pm 0.01 \text{ V}$  while measuring the current of  $5 \text{ mA}$  at  $300 \text{ K}$ , what will be the error in the value of current in  $\text{mA}$ ?  
 (1)  $0.2 \text{ mA}$                       (2)  $0.02 \text{ mA}$   
 (3)  $0.5 \text{ mA}$                       (4)  $0.05 \text{ mA}$
- From a tower of height  $H$ , a particle is thrown vertically upwards with a speed  $u$ . The time taken by the particle, to hit the ground, is  $n$  times that taken by it to reach the highest point of its path. The relation between  $H$ ,  $u$  and  $n$  is:  
 (1)  $2gH = n^2 u^2$                       (2)  $gH = \frac{n-2}{n} u^2$   
 (3)  $2gH = nu^2 \frac{n-2}{n}$                       (4)  $gH = \frac{n-2}{n} u^2$
- A mass ' $m$ ' is supported by a massless string wound around a uniform hollow cylinder of mass  $m$  and radius  $R$ . If the string does not slip on the cylinder, with what acceleration will the mass fall on release?

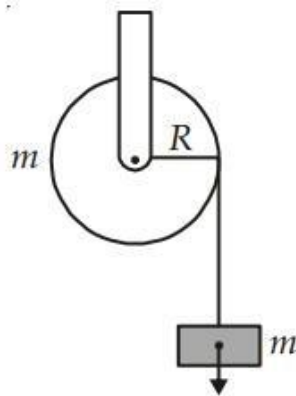

- |                    |                   |
|--------------------|-------------------|
| (1) $\frac{2g}{3}$ | (2) $\frac{g}{2}$ |
| (3) $\frac{5g}{6}$ | (4) $g$           |



4. A block of mass  $m$  is placed on a surface with a vertical cross-section given by  $y = \frac{x^3}{6}$ .

If the coefficient of friction is 0.5, the maximum height above the ground at which the block can be placed without slipping is:

- (1)  $\frac{1}{6} m$                       (2)  $\frac{2}{3} m$   
(3)  $\frac{1}{3} m$                       (3)  $\frac{1}{2} m$

5. When a rubber-band is stretched by a distance  $x$ , it exerts a restoring force of magnitude  $F = ax + bx^2$  where  $a$  and  $b$  are constants. The work done in stretching the unstretched rubber-band by  $L$  is:

- (1)  $aL^2 + bL^3$               (2)  $\frac{1}{2}(aL^2 + bL^3)$   
(3)  $\frac{aL^2}{2} + \frac{bL^3}{3}$               (4)  $\frac{1}{2}(aL^2 + bL^3)$

6. A bob of mass  $m$  attached to an inextensible string of length  $l$  is suspended from a vertical support. The bob rotates in a horizontal circle with an angular speed  $\omega$  rad / s about the vertical. About the point of suspension:

- (1) Angular momentum is conserved  
(2) Angular momentum changes in magnitude but not in direction  
(3) Angular momentum changes in direction but not in magnitude  
(4) Angular momentum changes both in direction and magnitude

7. Four particles, each of mass  $M$  and equidistant from each other, move along a circle of radius  $R$  under the action of their mutual gravitational attraction. The speed of each particle is:

- (1)  $\sqrt{\frac{GM}{R}}$                       (2)  $\sqrt{\frac{2\sqrt{2}GM}{R}}$   
(3)  $\sqrt{\frac{GM(1+2\sqrt{2})}{R}}$               (4)  $\frac{1}{2}\sqrt{\frac{GM(1+2\sqrt{2})}{R}}$



8. The pressure that has to be applied to the ends of a steel wire of length 10 cm to keep its length constant when its temperature is raised by  $100^\circ\text{C}$  is :

(For steel Young's modulus is  $2 \times 10^{11} \text{ Nm}^{-2}$  and coefficient of thermal expansion is  $1.1 \times 10^{-5} \text{ K}^{-1}$ )

- (1)  $2.2 \times 10^8 \text{ Pa}$                       (2)  $2.2 \times 10^9 \text{ Pa}$   
 (3)  $2.2 \times 10^7 \text{ Pa}$                       (4)  $2.2 \times 10^6 \text{ Pa}$
9. There is a circular tube in a vertical plane. Two liquids which do not mix and of densities  $d_1$  and  $d_2$  are filled in the tube. Each liquid subtends  $90^\circ$  angle at centre.

Radius joining their interface makes an angle  $\alpha$  with vertical. Ratio  $\underline{d_1}$  is:  $d_2$

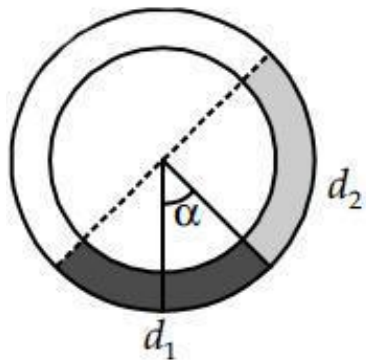

- (1)  $\frac{1 + \sin\alpha}{1 - \sin\alpha}$                       (2)  $\frac{1 + \cos\alpha}{1 - \cos\alpha}$   
 (3)  $\frac{1 + \tan\alpha}{1 - \tan\alpha}$                       (4)  $\frac{1 + \sin\alpha}{1 - \cos\alpha}$

10. On heating water, bubbles being formed at the bottom of the vessel detach and rise. Take the bubbles to be spheres of radius  $R$  and making a circular contact of radius  $r$  with the bottom of the vessel. If  $r \ll R$ , and the surface tension of water is  $T$ , value of  $r$  just before bubbles detach is (Density of water is  $\rho_w$ )

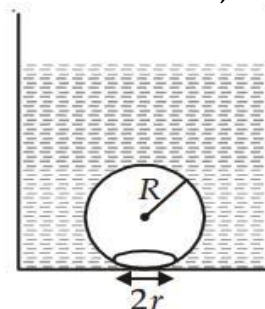



$$(1) R^2 \sqrt{\frac{\rho \omega g}{3T}}$$

$$(2) R^2 \sqrt{\frac{\rho \omega g}{6T}}$$

$$(3) R^2 \sqrt{\frac{\rho \omega g}{T}}$$

$$(4) R^2 \sqrt{\frac{3\rho \omega g}{T}}$$

11. Three rods of copper, brass and steel are welded section of each rod = 4 cm<sup>2</sup>. End of copper rod is maintained at 100°C whereas ends of brass and steel are kept at 0°C. Lengths of the copper, brass and steel rods are 46, 13 and 12 cm respectively. The rods are thermally insulated from surroundings except at ends. Thermal conductivities of copper, brass and steel are 0.92, 0.26 and 0.12 CGS units respectively. Rate of heat flow through copper rod is:
- (1) 1.2 cal/s                      (2) 2.4 cal/s  
(3) 4.8 cal/s                      (4) 6.0 cal/s
12. One mole of diatomic ideal gas undergoes a cyclic process ABC as shown in figure. The process BC is adiabatic. The temperatures at A, B and C are 400 K, 800 K and 600 K respectively. Choose the correct statement:

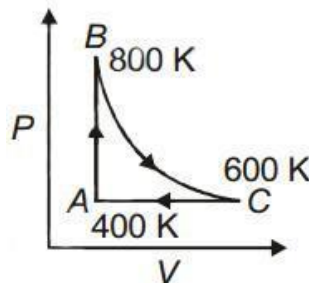

- (1) The change in internal energy in whole cyclic process is 250R  
(2) The change in internal energy in the process CA is 700R  
(3) The change in internal energy in the process AB is -350R  
(4) The change in internal energy in the process BC is - 500R
13. An open glass tube is immersed in mercury in such a way that a length of 8 cm extends above the mercury level. The open end of the tube is then closed and sealed and the tube is raised vertically up by additional 46 cm. What will be length of the air column above mercury in the tube now?  
(Atmospheric pressure = 76 cm of Hg)
- (1) 16 cm                      (2) 22 cm  
(3) 38 cm                      (4) 6 cm



14. A particle moves with simple harmonic motion in a straight line. In first  $\tau$  s, after starting from rest it travels a distance  $a$ , and in next  $\tau$  s it travels  $2a$  in same direction then:
- (1) Amplitude of motion is  $3a$
  - (2) Time period of oscillations is  $8\tau$
  - (3) Amplitude of motion is  $4a$
  - (4) Time period of oscillations is  $6\tau$
15. A pipe of length 85 cm is closed from one end. Find the number of possible natural oscillations of air column in the pipe whose frequencies lie below 1250 Hz. The velocity of sound in air is 340 m/s.
- (1) 12
  - (2) 8
  - (3) 6
  - (4) 4
16. Assume that an electric field  $E = 30x^2 \hat{i}$  exists in space. Then the potential difference  $V_A - V_0$ , where  $V_0$  is the potential at the origin and  $V_A$  the potential at  $x = 2$  m is:
- (1) 120 J
  - (2) -120 J
  - (3) -80 J
  - (4) 80 J
17. A parallel plate capacitor is made of two circular plates separated by a distance 5 mm and with a dielectric of dielectric constant 2.2 between them. When the electric field in the dielectric is  $3 \times 10^4$  V/m, the charge density of the positive plate will be close to
- (1)  $6 \times 10^{-7}$  C/m<sup>2</sup>
  - (2)  $3 \times 10^{-7}$  C/m<sup>2</sup>
  - (3)  $3 \times 10^4$  C/m<sup>2</sup>
  - (4)  $6 \times 10^4$  C/m<sup>2</sup>
18. In a large building, there are 15 bulbs of 40 W, 5 bulbs of 100 W, 5 fans of 80 W and 1 heater of 1 kW. The voltage of the electric mains is 220 V. The minimum capacity of the main fuse of the building will be :
- (1) 8 A
  - (2) 10 A
  - (3) 12 A
  - (4) 14 A



19. A conductor lies along the  $z$ -axis at  $-1.5 \leq z < 1.5$  m and carries a fixed current of 10.0 A in  $-\hat{z}$  direction (see figure). For a field  $B = 3.0 \times 10^{-4} e^{-0.2x} \hat{a}_y$  T, find the power required to move the conductor at constant speed to  $x = 2.0$  m,  $y = 0$  m in  $5 \times 10^{-3}$  s. Assume parallel motion along the  $x$ -axis.

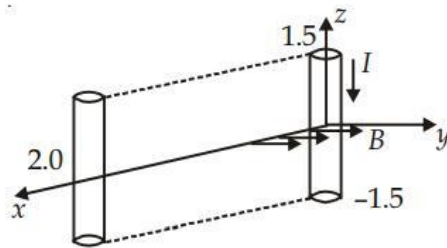

- (1) 1.57 W                      (2) 2.97 W  
(3) 14.85 W                    (4) 29.7 W
20. The coercivity of a small magnet where the ferromagnet gets demagnetized is  $3 \times 10^3$  A m $^{-1}$ . The current required to be passed in a solenoid of length 10 cm and number of turns 100, so that the magnet gets demagnetized when inside the solenoid, is:
- (1) 30 mA                      (2) 60 mA  
(3) 3 A                         (4) 6 A
21. In the circuit shown here, the point 'C' is kept connected to point 'A' till the current flowing through the circuit becomes constant. Afterward, suddenly, point 'C' is disconnected from point 'A' and connected to point 'B' at time  $t = 0$ . Ratio of the voltage across resistance and the inductor at  $t = L/R$  will be equal to:

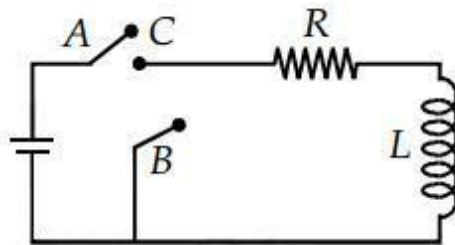

- (1)  $\frac{e}{1-e}$                       (2) 1  
(3) -1                         (4)  $\frac{1-e}{e}$



22. During the propagation of electromagnetic waves in a medium:

- (1) Electric energy density is double of the magnetic energy density
- (2) Electric energy density is half of the magnetic energy density
- (3) Electric energy density is equal to the magnetic energy density
- (4) Both electric and magnetic energy densities are zero

23. A thin convex lens made from crown glass  $\left( \mu = \frac{3}{2} \right)$  has focal length  $f$ . When it is

measured in two different liquids having refractive indices  $\frac{4}{3}$  and  $\frac{5}{3}$ , it has the focal

lengths  $f_1$  and  $f_2$  respectively. The correct relation between the focal lengths is:

- (1)  $f_1 = f_2 < f$
- (2)  $f_1 > f$  and  $f_2$  becomes negative
- (3)  $f_2 > f$  and  $f_1$  becomes negative
- (4)  $f_1$  and  $f_2$  both become negative

24. A green light is incident from the water to the air-water interface at the critical angle( $\theta$ ). Select the correct statement.

- (1) The entire spectrum of visible light will come out of the water at an angle of  $90^\circ$  to the normal.
- (2) The spectrum of visible light whose frequency is less than that of green light will come out to the air medium.
- (3) The spectrum of visible light whose frequency is more than that of green light will come out to the air medium.
- (4) The entire spectrum of visible light will come out of the water at various angles to the normal.

25. Two beams, A and B, of plane polarized light with mutually perpendicular planes of polarization are seen through a polaroid. From the position when the beam A has maximum intensity (and beam B has zero intensity), a rotation of polaroid through  $30^\circ$  makes the two beams appear equally bright. If the initial intensities of the two beams

are  $I^A$  and  $I^B$  respectively, then  $\frac{I^A}{I^B}$  equals:  $I^B$

- (1) 3
- (2)  $\frac{3}{2}$



- (3) 1                      (4)  $\frac{1}{3}$

26. The radiation corresponding to  $3 \rightarrow 2$  transition of hydrogen atoms falls on a metal surface to produce photoelectrons. These electrons are made to enter a magnetic field of  $3 \times 10^{-4}$  T. If the radius of the largest circular path followed by these electrons is 10.0 mm, the work function of the metal is close to:

- (1) 1.8 eV                      (2) 1.1 eV  
(3) 0.8 eV                      (4) 1.6 eV

27. Hydrogen ( ${}_1\text{H}^1$ ), Deuterium ( ${}_1\text{H}^2$ ), singly ionized Helium ( ${}_2\text{He}^4$ )<sup>+</sup> and doubly ionised lithium ( ${}_3\text{Li}^6$ )<sup>++</sup> all have one electron around the nucleus. Consider an electron transition from  $n = 2$  to  $n = 1$ . If the wave lengths of emitted radiation are  $\lambda_1, \lambda_2, \lambda_3$  and  $\lambda_4$  respectively then approximately which one of the following is correct?

- (1)  $4\lambda_1 = 2\lambda_2 = 2\lambda_3 = \lambda_4$   
(2)  $\lambda_1 = 2\lambda_2 = 2\lambda_3 = \lambda_4$   
(3)  $\lambda_1 = \lambda_2 = 4\lambda_3 = 9\lambda_4$   
(4)  $\lambda_1 = 2\lambda_2 = 3\lambda_3 = 4\lambda_4$

28. The forward biased diode connection is

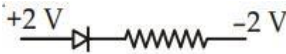
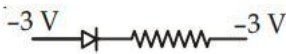
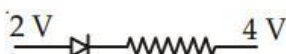
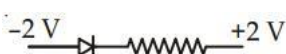
- (1) 
- (2) 
- (3) 
- (4) 



29. Match **List-I** (Electromagnetic wave type) with **List-II** (Its association/application) and select the correct option from the choices given below the lists :

<b>List-I</b>		<b>List-II</b>	
(a)	<b>Infrared waves</b>	(i)	<b>To treat muscular strain</b>
(b)	<b>Radio waves</b>	(ii)	<b>For broadcasting</b>
(c)	<b>X-rays</b>	(iii)	<b>To detect fracture of bones</b>
(d)	<b>Ultraviolet rays</b>	(iv)	<b>Absorbed by the ozone layer of the atmosphere</b>

- |     |            |            |            |            |
|-----|------------|------------|------------|------------|
|     | <b>(a)</b> | <b>(b)</b> | <b>(c)</b> | <b>(d)</b> |
| (1) | (iv)       | (iii)      | (ii)       | (i)        |
| (2) | (i)        | (ii)       | (iv)       | (iii)      |
| (3) | (iii)      | (ii)       | (i)        | (iv)       |
| (4) | (i)        | (ii)       | (iii)      | (iv)       |

30. A student measured the length of a rod and wrote it as 3.50 cm. Which instrument did he use to measure it?

- (1) A meter scale
- (2) A vernier calliper where the 10 divisions in vernier scale matches with 9 division in main scale and main scale has 10 divisions in 1 cm
- (3) A screw gauge having 100 divisions in the circular scale and pitch as 1 mm
- (4) A screw gauge having 50 divisions in the circular scale and pitch as 1 mm



**PART-B : CHEMISTRY**

31. The correct set of four quantum numbers for the valence electrons of rubidium atom ( $Z = 37$ ) is:

- (1)  $5, 0, 0, +\frac{1}{2}$                       (2)  $5, 1, 0, +\frac{1}{2}$   
(3)  $5, 1, 1, +\frac{1}{2}$                       (4)  $5, 0, 1, +\frac{1}{2}$

32. If  $Z$  is a compressibility factor, van der Waals equation at low pressure can be written as:

- (1)  $Z = 1 + \frac{RT}{PB}$                       (2)  $Z = 1 - \frac{a}{VRT}$   
(3)  $Z = 1 - \frac{Pb}{RT}$                       (4)  $Z = 1 + \frac{Pb}{RT}$

33. CsCl crystallises in body centred cubic lattice. If 'a' is its edge length then which of the following expressions is correct?

- (1)  $r_{Cs^+} + r_{Cl^-} = 3a$                       (2)  $r_{Cs^+} + r_{Cl^-} = \frac{3a}{2}$   
(3)  $r_{Cs^+} + r_{Cl^-} = \frac{\sqrt{3}}{2}a$                       (4)  $r_{Cs^+} + r_{Cl^-} = \sqrt{3}a$

34. For the estimation of nitrogen, 1.4 g of an organic compound was digested by Kjeldahl method and the evolved ammonia was absorbed in 60 mL of  $10^{\frac{M}{10}}$  sulphuric acid. The unreacted acid required 20 mL of  $10^{\frac{M}{10}}$  sodium hydroxide for complete neutralization. The percentage of nitrogen in the compound is:

- (1) 6%                      (2) 10%  
(3) 3%                      (4) 5%

35. Resistance of 0.2 M solution of an electrolyte is 50  $\Omega$ . The specific conductance of the solution is  $1.4 \text{ S m}^{-1}$ . The resistance of 0.5 M solution of the same electrolyte is 280  $\Omega$ . The molar conductivity of 0.5 M solution of the electrolyte in  $\text{S m}^2 \text{ mol}^{-1}$  is:



- (1)  $5 \times 10^{-4}$                       (2)  $5 \times 10^{-3}$   
(3)  $5 \times 10^3$                       (4)  $5 \times 10^2$

36. For complete combustion of ethanol,  $\text{C}_2\text{H}_5\text{OH}(l) + 3\text{O}_2(g) \rightarrow 2\text{CO}_2(g) + 3\text{H}_2\text{O}(l)$ , the amount of heat produced as measured in bomb calorimeter, is  $1364.47 \text{ kJ mol}^{-1}$  at  $25^\circ\text{C}$ . Assuming ideality the enthalpy of combustion,  $\Delta_c H$ , for the reaction will be: ( $R = 8.314 \text{ kJ mol}^{-1}$ )

- (1)  $-1366.95 \text{ kJ mol}^{-1}$     (2)  $-1361.95 \text{ kJ mol}^{-1}$   
(3)  $-1460.50 \text{ kJ mol}^{-1}$     (4)  $-1350.50 \text{ kJ mol}^{-1}$

37. The equivalent conductance of NaCl at concentration  $C$  and at infinite dilution are  $\lambda_c$  and  $\lambda_\infty$ , respectively. The correct relationship between  $\lambda_c$  and  $\lambda_\infty$  is given as:

(Where the constant  $B$  is positive)

- (1)  $\lambda_c = \lambda_\infty + (B)C$                       (2)  $\lambda_c = \lambda_\infty - (B)C$   
(3)  $\lambda_c = \lambda_\infty - (B)\sqrt{C}$                       (4)  $\lambda_c = \lambda_\infty + (B)\sqrt{C}$

38. Consider separate solutions of  $0.500 \text{ M C}_2\text{H}_5\text{OH}(aq)$ ,  $0.100 \text{ M Mg}_3(\text{PO}_4)_2 (aq)$ ,  $0.250 \text{ M KBr}(aq)$  and  $0.125 \text{ M Na}_3\text{PO}_4(aq)$  at  $25^\circ\text{C}$ . Which statement is true about these solutions, assuming all salts to be strong electrolytes?

- (1) They all have the same osmotic pressure.  
(2)  $0.100 \text{ M Mg}_3(\text{PO}_4)_2 (aq)$  has the highest osmotic pressure.  
(3)  $0.125 \text{ M Na}_3\text{PO}_4 (aq)$  has the highest osmotic pressure  
(4)  $0.500 \text{ M C}_2\text{H}_5\text{OH} (aq)$  has the highest osmotic pressure.

39. For the reaction  $\text{SO}_2(g) + \frac{1}{2}\text{O}_2(g) \rightleftharpoons \text{SO}_3(g)$  if  $K_p = K_c (RT)^x$  where the symbols have usual

meaning then the value of  $x$  is:  
(assuming ideality)

- (1)  $-1$                       (2)  $-\frac{1}{2}$   
(3)  $\frac{1}{2}$                       (4)  $1$



40. For the non-stoichiometre reaction  $2A + B \rightarrow C + D$ , the following kinetic data were obtained in three separate experiments, all at 298 K.

Initial Concentration (A)	Initial Concentration (B)	Initial rate of formation of C ( $\text{mol L}^{-1} \text{s}^{-1}$ )
0.1 M	0.1 M	$1.2 \times 10^{-3}$
0.1 M	0.2 M	$1.2 \times 10^{-3}$
0.2 M	0.1 M	$2.4 \times 10^{-3}$

The rate law for the formation of C is

(1)  $\frac{dC}{dt} = k[A][B]$

(2)  $\frac{dC}{dt} = k[A]^2[B]$

(3)  $\frac{dC}{dt} = k[A][B]^2$

(4)  $\frac{dC}{dt} = k[A]$

41. Among the following oxoacids, the correct decreasing order of acid strength is:

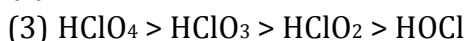
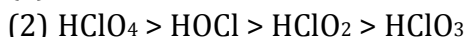
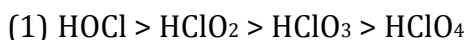

42. The metal that cannot be obtained by electrolysis of an aqueous solution of its salts is:



43. The octahedral complex of a metal ion  $M^{3+}$  with four monodentate ligands  $L_1$ ,  $L_2$ ,  $L_3$  and  $L_4$  absorb wavelengths in the region of red, green, yellow and blue, respectively. The increasing order of ligand strength of the four ligands is

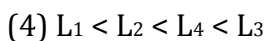
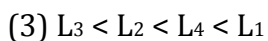
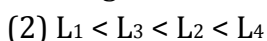
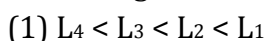

44. Which one of the following properties is **not** shown by  $\text{NO}$ ?

(1) It is diamagnetic in gaseous state

(2) It is a neutral oxide

(3) It combines with oxygen to form nitrogen dioxide

(4) It's bond order is 2.5



45. In which of the following reactions  $\text{H}_2\text{O}_2$  acts as a reducing agent?

- (a)  $\text{H}_2\text{O}_2 + 2\text{H}^+ + 2\text{e}^- \rightarrow 2\text{H}_2\text{O}$
  - (b)  $\text{H}_2\text{O}_2 - 2\text{e}^- \rightarrow \text{O}_2 + 2\text{H}^+$
  - (c)  $\text{H}_2\text{O}_2 + 2\text{e}^- \rightarrow 2\text{OH}^-$
  - (d)  $\text{H}_2\text{O}_2 + 2\text{OH}^- - 2\text{e}^- \rightarrow \text{O}_2 + 2\text{H}_2\text{O}$
- (1) (a), (b)  
(2) (c), (d)  
(3) (a), (c)  
(4) (b), (d)

46. The correct statement for the molecule,  $\text{CsI}_3$ , is:

- (1) It is a covalent molecule
- (2) It contains  $\text{Cs}^+$  and  $\text{I}_3^-$  ions
- (3) It contains  $\text{Cs}^{3+}$  and  $\text{I}^-$  ions
- (4) It contains  $\text{Cs}^+$ ,  $\text{I}^-$  and lattice  $\text{I}_2$  molecule

47. The ratio of masses of oxygen and nitrogen in a particular gaseous mixture is 1 : 4. The ratio of number of their molecule is:

- (1) 1 : 4
- (2) 7 : 32
- (3) 1 : 8
- (4) 3 : 16

48. Given below are the half-cell reactions:

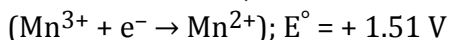

The  $E^\circ$  for  $3 \text{Mn}^{2+} \rightarrow \text{Mn} + 2\text{Mn}^{3+}$  will be:

- (1) -2.69 V; the reaction will not occur
- (2) -2.69 V; the reaction will occur
- (3) -0.33 V; the reaction will not occur
- (4) -0.33 V; the reaction will occur

49. Which series of reactions correctly represents chemical reactions related to iron and its compound?

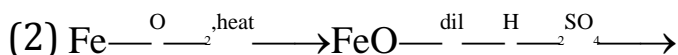
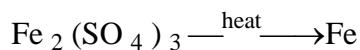
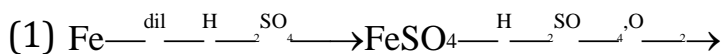

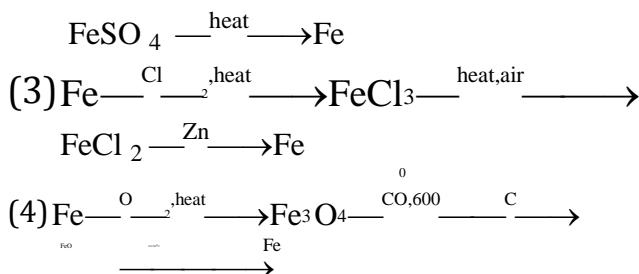

50. The equation which is balanced and represents the correct product (s) is:

- (1)  $\text{Li}_2\text{O} + 2\text{KCl} \rightarrow 2\text{LiCl} + \text{K}_2\text{O}$
- (2)  $[\text{CoCl}(\text{NH}_3)_5]^+ + 5\text{H}^+ \rightarrow \text{Co}^{2+} + 5\text{NH}_4^+ + \text{Cl}^-$
- (3)  $[\text{Mg}(\text{H}_2\text{O})_6]^{2+} + (\text{EDTA})^{4-} \xrightarrow{\text{excess NaOH}} [\text{Mg}(\text{EDTA})]^{2-} + 6\text{H}_2\text{O}$
- (4)  $\text{CuSO}_4 + 4\text{KCN} \rightarrow \text{K}_2[\text{Cu}(\text{CN})_4] + \text{K}_2\text{SO}_4$

51. In  $\text{S}_{\text{N}}2$  reactions, the correct order of reactivity for the following compounds:  $\text{CH}_3\text{Cl}$ ,  $\text{CH}_3\text{CH}_2\text{Cl}$ ,  $(\text{CH}_3)_2\text{CHCl}$  and  $(\text{CH}_3)_3\text{CCl}$  is:

- (1)  $\text{CH}_3\text{Cl} > (\text{CH}_3)_2\text{CHCl} > \text{CH}_3\text{CH}_2\text{Cl} > (\text{CH}_3)_3\text{CCl}$
- (2)  $\text{CH}_3\text{Cl} > \text{CH}_3\text{CH}_2\text{Cl} > (\text{CH}_3)_2\text{CHCl} > (\text{CH}_3)_3\text{CCl}$
- (3)  $\text{CH}_3\text{CH}_2\text{Cl} > \text{CH}_3\text{Cl} > (\text{CH}_3)_2\text{CHCl} > (\text{CH}_3)_3\text{CCl}$
- (4)  $(\text{CH}_3)_2\text{CHCl} > \text{CH}_3\text{CH}_2\text{Cl} > \text{CH}_3\text{Cl} > (\text{CH}_3)_3\text{CCl}$

52. On heating an aliphatic primary amine with chloroform and ethanolic potassium hydroxide, the organic compound formed is

- (1) an alcohol
- (2) an alkanediol
- (3) an alkyl cyanide
- (4) an alkyl isocyanide

53. The most suitable reagent for the conversion of  $\text{R}-\text{CH}_2-\text{OH} \rightarrow \text{R}-\text{CHO}$  is:

- (1)  $\text{KMnO}_4$
- (2)  $\text{K}_2\text{Cr}_2\text{O}_7$
- (3)  $\text{CrO}_3$
- (4) PCC (Pyridinium Chlorochromate)

54. The major organic compound formed by the reaction of 1, 1, 1-trichloroethane with silver powder is:



- (1) Acetylene                      (2) Ethene  
(3) 2-Butyne                      (4) 2-Butene

55. Sodium phenoxide when heated with  $\text{CO}_2$  under pressure at  $125^\circ\text{C}$  yields a product which on acetylation produces C.

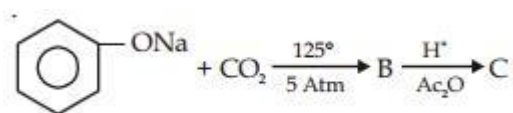

The major product C would be:

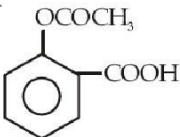
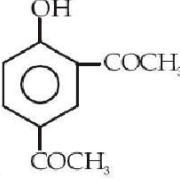
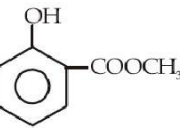
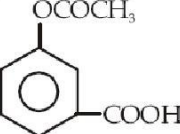
- (1)  (2) 
- (3)  (4) 



56. Considering the basic strength of amines in aqueous solution, which one has the smallest  $pK_b$  value?

- (1)  $(CH_3)_2NH$                       (2)  $CH_3NH_2$   
(3)  $(CH_3)_3N$                       (4)  $C_6H_5NH_2$

57. For which of the following molecule significant  $\mu \neq 0$ ?

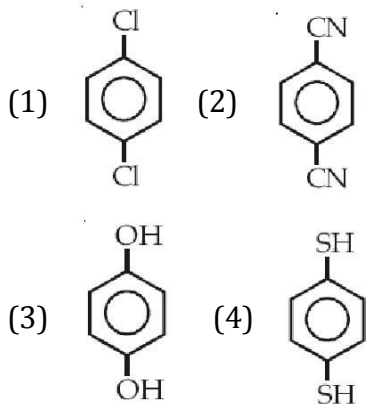

58. Which one is classified as a condensation polymer?

- (1) Dacron                      (2) Neoprene  
(3) Teflon                      (4) Acrylonitrile

59. Which one of the following bases is not present in DNA?

- (1) Quinoline                      (2) Adenine  
(3) Cytosine                      (4) Thymine

60. In the reaction,

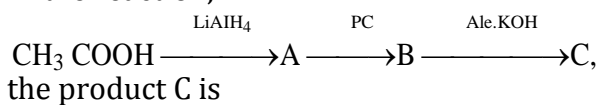

- (1) Acetaldehyde                      (2) Acetylene  
(3) Ethylene                      (4) Acetyl chloride





**SCHOOL**  
**COMMUNE**



65. If  $\alpha, \beta \neq 0$ , and  $f(n) = \alpha n + \beta n$  and

$$\begin{vmatrix} \beta & 1+f(1) & 1+f(2) \\ 1+f(1) & 1+f(2) & 1+f(3) \\ 1+f(2) & 1+f(3) & 1+f(4) \end{vmatrix} = K(1-\alpha)^2(1-\beta)^2(\alpha-\beta)^2, \text{ then } K \text{ is equal to:}$$

- (1) 1                      (2) -1  
(3)  $\alpha\beta$                   (4)  $\frac{1}{\alpha\beta}$

66. If  $A$  is an  $3 \times 3$  non-singular matrix such that  $AA' = A'A$  and  $A = -'1 B A A$ , then  $BB'$  equals:

- (1)  $B^{-1}$                   (2)  $(B^{-1})'$   
(3)  $I + B$                 (4)  $I$

67. If the coefficients of  $x^3$  and  $x^4$  in the expansion of  $(1 + ax + bx^2)(1 - 2x)^{18}$  in powers of  $x$  are both zero, then  $(a, b)$  is equal to:

- (1)  $\left(14, \frac{272}{3}\right)$           (2)  $\left(16, \frac{272}{3}\right)$   
(3)  $\left(16, \frac{251}{3}\right)$           (4)  $\left(14, \frac{251}{3}\right)$

68. If  $(10)^9 + 2(11)^1(10)^8 + 3(11)^2(10)^7 + \dots + 10(11)^9 = k(10)^9$ , then  $k$  is equal to:

- (1) 100                    (2) 110  
(3)  $\frac{221}{10}$                     (4)  $\frac{441}{100}$

69. Three positive numbers form an increasing G.P. If the middle term in this G.P. is doubled, the new numbers are in A.P. Then the common ratio of the G.P. is:

- (1)  $2 - \sqrt{3}$               (2)  $2 + \sqrt{3}$   
(3)  $\sqrt{2} + \sqrt{3}$           (4)  $3 + \sqrt{2}$

70.  $\lim_{x \rightarrow 0} \frac{\sin(\pi \cos^2 x)}{x^2}$  is equal to:

- (1)  $-\pi$                     (2)  $\pi$   
(3)  $\frac{\pi}{2}$                         (4) 1



71. If  $g$  is the inverse of a function  $f$  and  $f'(x) = \frac{1}{1+x^5}$  then  $g'(x)$  is equal to:

- (1)  $\frac{1}{1+\{g(x)\}^5}$       (2)  $1+\{g(x)\}^5$   
(3)  $1+x^5$               (4)  $5x^4$

72. If  $f$  and  $g$  are differentiable functions in  $[0, 1]$  satisfying  $f(0) = 2 = g(1)$ ,  $g(0) = 0$  and  $f(1) = 6$ , then for some  $c \in ]0, 1[$ :

- (1)  $f'(c) = g'(c)$               (2)  $f'(c) = 2g'(c)$   
(3)  $2f'(c) = g'(c)$               (4)  $2f'(c) = 3g'(c)$

73. If  $x = -1$  and  $x = 2$  are extreme points of  $f(x) = \alpha \log |x| + \beta x^2 + x$  then:

- (1)  $\alpha = 2, \beta = -\frac{1}{2}$               (2)  $\alpha = 2, \beta = \frac{1}{2}$   
(3)  $\alpha = -6, \beta = \frac{1}{2}$               (4)  $\alpha = -6, \beta = -\frac{1}{2}$

74. The integral  $\int \left(1+x - \frac{1}{x}\right) |e^{x+1x}| dx$  is equal to:

- (1)  $(x+1)e^{\frac{x+1}{x}} + C$               (2)  $-xe^{\frac{x+1}{x}} + C$   
(3)  $(x-1)e^{\frac{x+1}{x}} + C$               (4)  $xe^{\frac{x+1}{x}} + C$

75. The integral

$$\int_0^{\pi} \sqrt{1+4\sin^2 \frac{2x}{2} - 4\sin \frac{x}{2}} dx \text{ equals:}$$

- (1)  $4\sqrt[3]{-4}$               (2)  $4\sqrt[3]{-4} - \frac{\pi}{3}$   
(3)  $\pi - 4$               (4)  $\frac{2\pi}{3} - 4 - 4\sqrt[3]{-4}$

76. The area of the region described by  $A = \{(x, y) : x^2 + y^2 \leq 1 \text{ and } y^2 \leq 1 - x\}$  is:

- (1)  $\frac{\pi}{2} - \frac{2}{3}$               (2)  $\frac{\pi}{2} + \frac{2}{3}$   
(3)  $\frac{\pi}{2} + \frac{4}{3}$               (4)  $\frac{\pi}{2} - \frac{4}{3}$



77. Let the population of rabbits surviving at a time  $t$  be governed by the differential equation

$$\frac{dp(t)}{dt} = \frac{1}{2}p(t) - 200. \text{ If } p(0) = 100, \text{ then } p(t) \text{ equals:}$$

- (1)  $600 - 500 e^{t/2}$       (2)  $400 - 300 e^{-t/2}$   
(3)  $400 - 300 e^{t/2}$       4)  $300 - 200 e^{-t/2}$

78. Let PS be the median of the triangle with vertices P(2, 2), Q(6, -1) and R (7, 3). The equation of the line passing through (1, -1) and parallel to PS is:

- (1)  $4x + 7y + 3 = 0$       (2)  $2x - 9y - 11 = 0$   
(3)  $4x - 7y - 11 = 0$       (4)  $2x + 9y + 7 = 0$

79. Let a, b, c and d be non-zero numbers. If the point of intersection of the lines  $4ax + 2ay + c = 0$  and  $5bx + 2by + d = 0$  lies in the fourth quadrant and is equidistant from the two axes then:

- (1)  $3bc - 2ad = 0$       (2)  $3bc + 2ad = 0$   
(3)  $2bc - 3ad = 0$       (4)  $2bc + 3ad = 0$

80. The locus of the foot of perpendicular drawn from the centre of the ellipse  $x^2 + 3y^2 = 6$  on any tangent to it is;

- (1)  $(x^2 + y^2)^2 = 6x^2 + 2y^2$       (2)  $(x^2 + y^2)^2 = 6x^2 - 2y^2$   
(3)  $(x^2 - y^2)^2 = 6x^2 + 2y^2$       (4)  $(x^2 - y^2)^2 = 6x^2 - 2y^2$

81. Let C be the circle with centre at (1, 1) and radius = 1. If T is the circle centred at (0, y), passing through origin and touching the circle C externally, then the radius of T is equal to:

- (1)  $\frac{1}{2}$       (2)  $\frac{1}{4}$   
(3)  $\frac{\sqrt{3}}{\sqrt{2}}$       (4)  $\frac{\sqrt{3}}{2}$

82. The slope of the line touching both the parabolas  $y^2 = 4x$  and  $x^2 = -32y$  is:

- (1)  $\frac{1}{8}$       (2)  $\frac{2}{3}$   
(3)  $\frac{1}{2}$       (4)  $\frac{3}{2}$



83. The image of the line  $\frac{x-1}{3} = \frac{y-3}{1} = \frac{z-4}{-5}$  in the plane  $2x - y + z + 3 = 0$  is the line:

(1)  $\frac{x-3}{3} = \frac{y+5}{1} = \frac{z-2}{-5}$

(2)  $\frac{x-3}{-3} = \frac{y+5}{-1} = \frac{z-2}{5}$

(3)  $\frac{x+3}{3} = \frac{y-5}{1} = \frac{z-2}{-5}$

(4)  $\frac{x+3}{-3} = \frac{y-5}{-1} = \frac{z+2}{5}$

84. The angle between the lines whose direction cosines satisfy the equations  $l + m + n = 0$  and  $l^2 = m^2 + n^2$  is:

(1)  $\frac{\pi}{6}$                       (2)  $\frac{\pi}{2}$

(3)  $\frac{\pi}{3}$                       (4)  $\frac{\pi}{4}$

85. If  $\left[ \begin{matrix} a & \times & b \\ b & \times & c \\ c & \times & a \end{matrix} \right] = \lambda \left[ \begin{matrix} a & b & c \\ b & c & a \\ c & a & b \end{matrix} \right]^2$  then  $\lambda$  is equal to:

(1) 0                      (2) 1

(3) 2                      (4) 3

86. Let A and B be two events such that  $P(\overline{A \cup B}) = \frac{1}{6}$ ,  $P(A \cap B) = \frac{1}{4}$  and  $P(\overline{A}) = \frac{1}{4}$ ,

where  $\overline{A}$  stands for the complement of the event A. Then the events A and B are:

- (1) Independent but not equally likely
- (2) Independent and equally likely
- (3) Mutually exclusive and independent
- (4) Equally likely but not independent

87. The variance of first 50 even natural numbers is:

(1) 437                      (2)  $\frac{437}{4}$

(3)  $\frac{833}{4}$                       (4) 833

88. Let  $f_k(x) = \frac{1}{k}(\sin^k x + \cos^k x)$  where  $x \in \mathbb{R}$  and  $k \geq 1$ . Then

$f_4(x) - f_6(x)$  equals:

(1)  $\frac{1}{4}$                       (2)  $\frac{1}{12}$



SCHOOL  
COMMUNE

(3)  $\frac{1}{6}$

(4)  $\frac{1}{3}$

89. A bird is sitting on the top of a vertical pole 20 m high and its elevation from a point O on the ground is  $45^\circ$ . It flies off horizontally straight away from the point O. After one second, the elevation of the bird from O is reduced to  $30^\circ$ . Then the speed (in m/s) of the bird is:

(1)  $20\sqrt{2}$       (2)  $20(\sqrt{3}-1)$

(3)  $40(\sqrt{2}-1)$       (4)  $40(\sqrt{3}-\sqrt{2})$

90. The statement  $\sim(p \leftrightarrow \sim q)$  is:

(1) A tautology

(2) A fallacy

(3) Equivalent to  $p \leftrightarrow q$

(4) Equivalent to  $\sim p \leftrightarrow q$



**SCHOOL**  
**COMMUNE**